

B35D 6x6 **ARTICULATED DUMP TRUCK** MK VI



Gross Power: 290 kw (389 hp)
Gross Torque: 1 850 Nm (1,4362 lbft)
Rated Payload: 32 500 kg (71,650 lbs)



B35D 6x6 ARTICULATED DUMP TRUCK MKVI

ENGINE

Mercedes Benz V6, turbocharged, intercooled, low emission diesel engine
Gross power 290 kW (389 hp) @ 1 800 rpm
Net Power 283 kW (380 hp) @ 1 800 rpm
Gross torque 1 850 Nm (1,362 lbf) @ 1 300 rpm
Net torque 1 824 Nm (1,343 lbf) @ 1 300 rpm
Displacement 11,95 litres (730 cu.in)
Fuel tank capacity 485 litres (128 US gal)
Auxiliary Brake Automatic exhaust brake Engine Valve Brake (EVB)
Certification Non Regulated OM 501 LA.E2/1-00 meets Europe (EU) step2;
Regulated OM 501 LA.E3A/1 meets Europe (EU) step 3

TRANSMISSION

Engine mounted, fully automatic Allison planetary transmission with six forward gears and one reverse gear. Hydrodynamic with lock-up in all gears.
Torque Converter
Model 4500R ORS
Control Type Electronic

TRANSFER BOX

Remote mounted
Manufacturer VGR
Model 17100
Layout Three in-line helical gears.
Output Differential Interaxle 33/67 proportional differential, Pneumatically lockable whilst stationary or on the move

AXLES

High strength steel fabricated with spiral bevel type gears on the Controlled Traction differential and heavy duty outboard planetary gears.

Model Brakes

Bell 25T
 Dual circuit, hydraulically actuated dry disc brakes on all three axles.

Max brake force Parking Brake

193 kN (43,388 lbf)
 Spring applied, air released driveline mounted disc.

Max brake force Total Retardation

440 kN (98,920 lbf)
 575 kW (771 hp)

WHEELS

Tyre Earthmover 26.5R25



FRONT SUSPENSION

Semi-independent, leading A-frame supported by nitrogen/oil struts

REAR SUSPENSION

Pivoting walking beams equalize the load on each axle with laminated suspension blocks. Each axle is coupled to the chassis by a Tri-Link system of four rubber-bushed links for ideal vertical movement and a transverse link for lateral restraint.

HYDRAULIC SYSTEM

Variable displacement with load sensing system incorporating a ground driven emergency steering pump.
Flow 300 l/min (79,26 gal/min)
Pressure 25 Mpa (3,626 psi)
Filter 10 micron

STEERING SYSTEM

Hydrostatically actuated by two double acting cylinders, with ground-driven emergency steering pump.

Lock to lock turns Steering Angle

4.7
 +-42°

DUMPING SYSTEM

Two double-acting, single stage, dump cylinders
Raise Time 13 s
Lowering Time 7,6 s
Tipping Angle 70°

PNEUMATIC SYSTEM

Air drier with heater and integral unloader valve, serving park brake and auxiliary functions
System Pressure 810 kPa (117 psi)

ELECTRICAL SYSTEM

Voltage 24 V
Battery Type Two maintenance free permanently sealed
Battery Capacity 2 X 105 Ah
Alternator Rating 28 V 100 A

VEHICLE SPEEDS

1st	8	5
2nd	17	10.6
3rd	24	15
4th	37	23
5th	48	30
6th	54	33.8
R	6,3 km/h	3.9 mph



B35D 6x6 ARTICULATED DUMP TRUCK MkVI

LOAD CAPACITY & GROUND PRESSURE

WEIGHTS			GROUND PRESSURE			LOAD CAPACITY		
UNLADEN	kg	lbs	UNLADEN	kPa	psi	BODY	m³	cu.yd
Front	14,120	31,129	Front	108	15.7	Struck Capacity	15,9	20.8
Middle	7,060	15,565	Middle	58	8.4	SAE 2:1 Capacity	20,1	26.3
Rear	7,050	15,543	Rear	58	8.4	SAE 1:1 Capacity	24,6	32.2
Total	28,230	62,236				SAE 2:1 Capacity with Autogate	20,7	27.1
LADEN			LADEN					
Front	18,350	40,455	Front	303	44			
Middle	21,195	46,727	Middle	338	49	Rated Payload	32,500 kg	71,650 lbs
Rear	21,185	46,705	Rear	338	49			
Total	60,730	133,887						

GRADEABILITY/RIMPULL

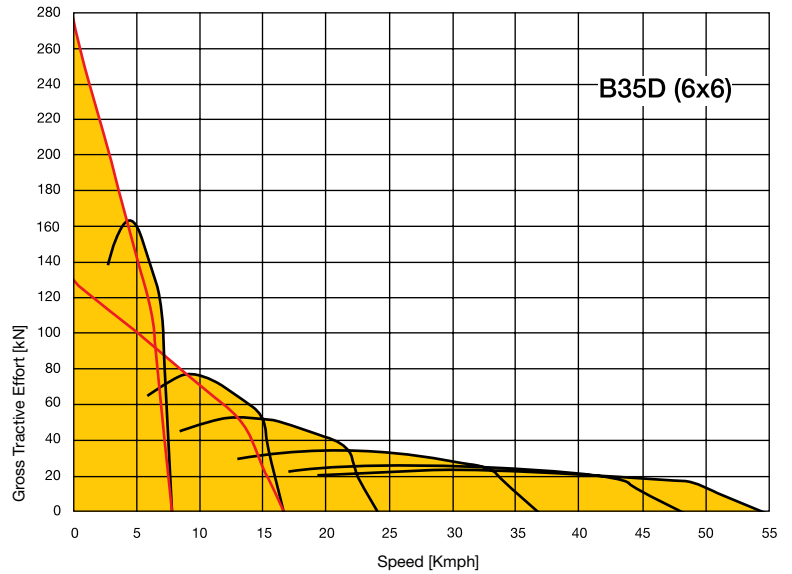
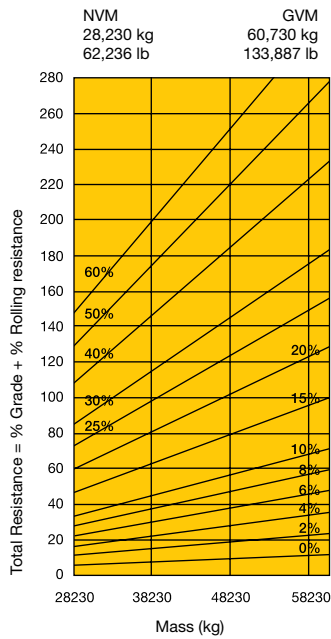

RETARDATION

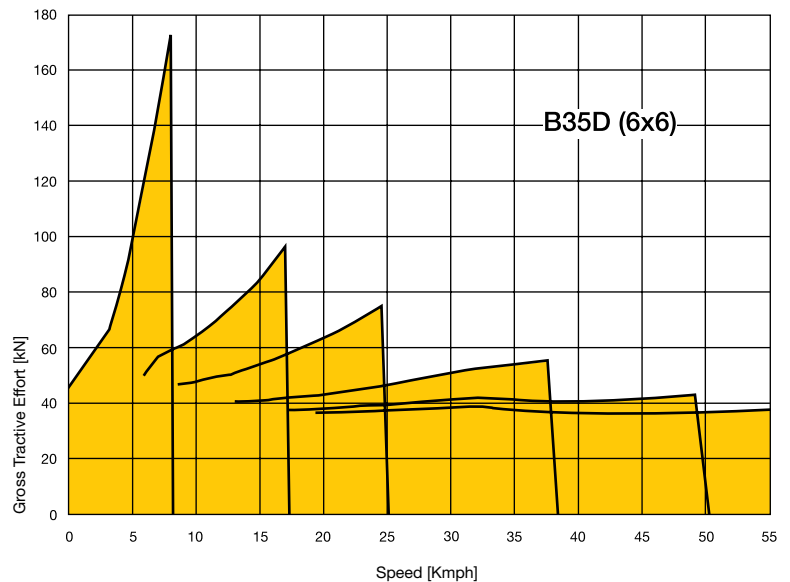
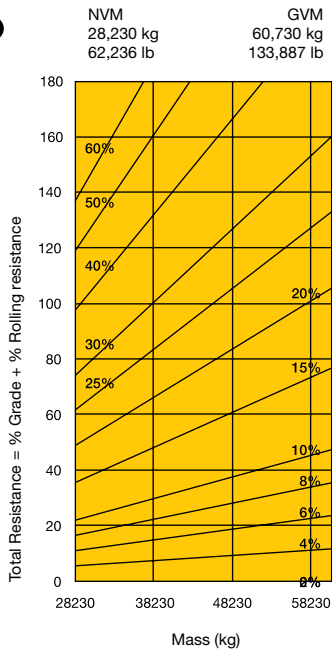

B35D 6x6 ARTICULATED DUMP TRUCK MKVI

DIMENSIONS

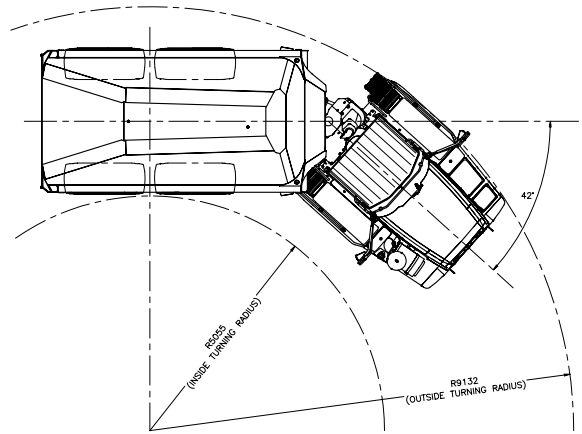
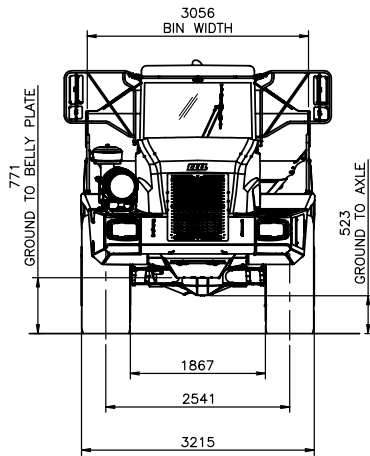
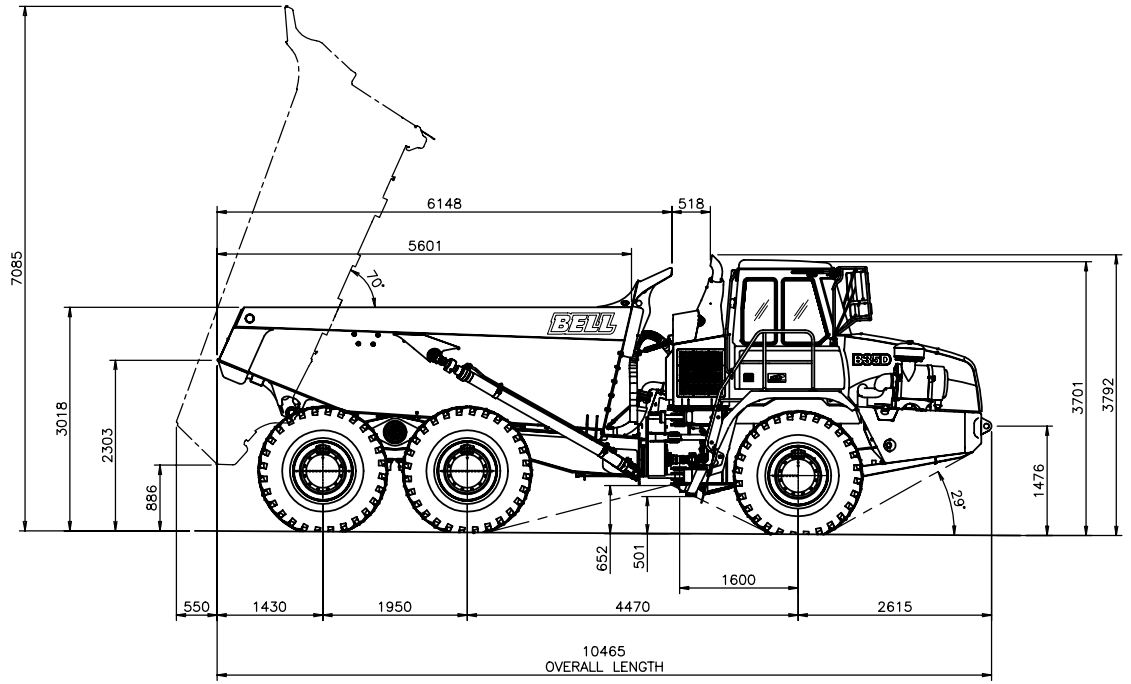

B35D 6x6 ARTICULATED DUMP TRUCK

MKVI

AVAILABLE EQUIPMENT*

Cab

- ROPS/FOPS certification
- Protective rear window guard
- Tilt cab for service access
- Gas strut supported door
- Tinted safety glass
- Sliding windows
- Rear view mirrors- regular and wide angle
- Electrically adjustable rearview mirrors - one per side
- Sun visor
- Wiper/washer with intermittent control
- Tilt and telescoping steering wheel
- Adjustable, air suspension seat with retractable seat belt
- Fold-away trainer seat with retractable seat belt
- HVAC climate control system with filtered and ducted air
- Rotating beacon
- 12 V power outlet/12 V cigarette lighter
- Ash tray
- Drinks holder
- Cooled/heated lunch box
- I-Tip programmable bin tip
- Sound insulated to 76 dB(A) to ISO 6396
- Radio/CD/Tape
- Memory Module
- Air horn

MDU Features

- Operator / Site selected speed control
- Tipping counter
- Trip timer
- Trip distance
- On Board Weigh System (OBW)
- Transmission gear selection
- Fuel Consumption
- Diagnostics
- Intermittent wiper timing control
- Speedo calibration for alternative tyre sizes

Gauges

- Metric /Imperial unit selection
- Warning lights with audible buzzer

Vehicle

- Engine coolant temperature
- Engine oil pressure
- Transmission oil temperature
- Fuel
- Tachometer
- Battery voltage
- Hourmeter
- Odometer
- System air pressure

Other

- Ground driven emergency steering
 - Bin safety prop
 - Articulation lock
 - Integral transmission output retarder with 6 settings
- (Factory or field installed)
- Groeneveld auto greasing system
 - Retractable sun visor
 - Exhaust body heating
 - Autogate
 - Body liners
 - Fleetmatic Satellite Monitoring System
 - Driver ID and immobiliser
 - Forward working lights
 - Artic reverse light
 - Fuel heater
 - External windshield visor
 - Headlight protection grills
 - Rear window wiper
 - Antenna mounting bracket
 - System for reverse camera
 - Wiggins quick fuelling system
 - Comfort ride suspension system
 - Tyre pressure monitoring
 - Full handrail kit

*standard specification for machines may vary according to region



What makes the B35D a great performer...

- **With a highly efficient power and drivetrain combined with low rolling resistance, the Bell B35D delivers superior fuel efficiency**
- **High performance engine with increased power and torque and long service intervals**
- **Powerful hydraulic transmission retarder drastically cuts brake use extending pad life up to a factor of five**
- **Fewer scheduled service requirements**
- **Supreme driver comfort from a nitrogen over oil strut independent suspension system**
- **Deluxe cab - setting new standards in comfort, sound levels and simplicity in operation**
- **Electronic component protection**
- **Easy service access**
- **Fast tip cycles**
- **Low ground pressure to work jobs other trucks can't**
- **Comfort Ride option with adaptive front suspension and dual stage rear suspension**

BELL INTERNATIONAL: Tel: +27 (0) 35-907 9431



Tel: +33 (0) 5 55 89 23 56



Tel: +49 (0) 6631 / 91 13 - 0



Tel: +34 91 879 60 19



Tel: +27 (0) 11-928-9700

UK Tel: +44 (0) 1283 712862

E-mail: sales@bellequipment.com

• www.bellequipment.com

All dimensions are shown in millimetres, unless otherwise stated between brackets. Under our policy of continuous improvement, we reserve the right to change specifications and design without prior notice. Photographs featured in this brochure may include optional equipment.

**Strong Reliable Machines
Strong Reliable Support**

BELL